

Application Note 437 – Providing Short Interval – High Output Power

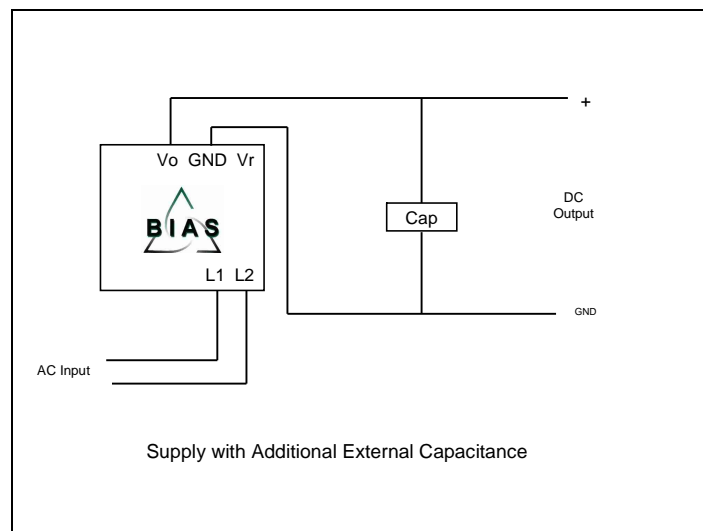

Applications where the average power required by the load falls within the power ratings of a Bias Power supply but there are short interval - high power requirements, Bias Power supply outputs can be modified to meet these requirements. A typical situation where this may occur is in powering a motor or solenoid. As shown in the figure below, adding capacitance to the output of the power supply will increase the storage of power on the output of the supply.



When operating within the power rating of the supply, it provides enough power to charge the output capacitor to the rated voltage. The supply charges the output capacitors at a regular interval (twice the AC input frequency). When a short interval – high power load occurs, it will cause the output voltage to droop as it draws power from the output capacitors. The supply will output power pulses and charge the output capacitors as much as possible on each charge cycle until the voltage across the output capacitors reaches the rated output voltage. Additional capacitance, such as found in a super capacitor, allows the output capacitors to store more power. This condition will have no adverse effect on the power supply and can be far more effective than moving to a higher wattage supply.

For more information email (www.biaspower.com) or call Dr. Bias (+1 847.215.2427)