



BIAS Power Supply Module BPS 0.5 Series Data Sheet



Actual Size

The BPS 0.5 Power Supply Module is an ideal replacement for current standby power applications in appliances and consumer electronics. Also appropriate for low-power industrial and commercial applications. This low-cost supply provides up to one half watt of output power at 8 or 14 VDC (V_o) and an optional 5 VDC (V_r) output to power standby functions such as a clock, microprocessor or remote control sensor. Incorporating a custom integrated circuit into a small package (0.5 in³ [8.0 cm³]) the BIAS Module provides an immediate “drop-in” solution, requiring no additional external components.

Operating Specifications

(@120VAC / 60 Hz / 25°C unless otherwise specified)

Electrical	
Input Voltage Range	85 - 265 VAC (50/60Hz)
Input Surge Withstand	308V, < 30 sec
Output Power (Pmax)	0.5 W min. (60Hz) 0.43 W min. (50Hz)
Efficiency	75% nom.
Output V_o (Peak)	8 or 14 VDC nom. +/- 5%
Line / Load Regulation V_o (Peak)	+/- 1% $P_o < P_{max}$
Temperature Regulation V_o (Peak)	+/- 2% $P_o < P_{max}$
Ripple V_o (@ 120 Hz) (@ 100 kHz)	1.00 V p:p 0.25 V p:p
Output V_r	5 VDC +/- 5%, I_r out 75mA max $I_{out} + I_r$ out <= 75mA
No-load Consumption	30 mW typical @ V_{in} =120 VAC
Isolation	3000 VAC (meets UL / CSA & EN Product Safety)
Earth Leakage @ 120 VAC	< 10 uA
Short Circuit Protection	Continuous, $P_{in} = 0.6$ w @ $V_{in} = 120$ VAC
Reliability @ 25° C	> 200 Khr MTBF
Thermal	
Operating Temperature	0 to 70° C
Operating Relative Humidity	0 – 95%, non-condensing
Storage Temperature	-40 to 105° C
Mechanical	
Package Size (L x W x H)	1.03 x 0.89 x 0.53 inches [26.2 x 22.6 x 13.5 mm]
Safety	
Safety Compliance ²	UL / EN 60950 (CB Report Available)
EMI Emissions	EN 55022, Class B, FCC Part 15, Class B

Features

- Universal Input (85-265 VAC, 50/60Hz)
- Small Size—0.5in³ [8.0cm³]
- Single Component Solution
- Very low no-load input power <30mW
- 3000 VAC Isolation
- Up to 75% efficiency
- EN 55022, Class B; FCC Part 15, Class B
- Meets UL/CSA and EN Product Safety Requirements (ITE)

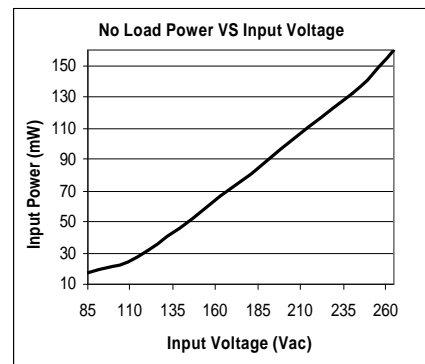



BIAS Power Supply Module BPS 0.5 Series Data Sheet

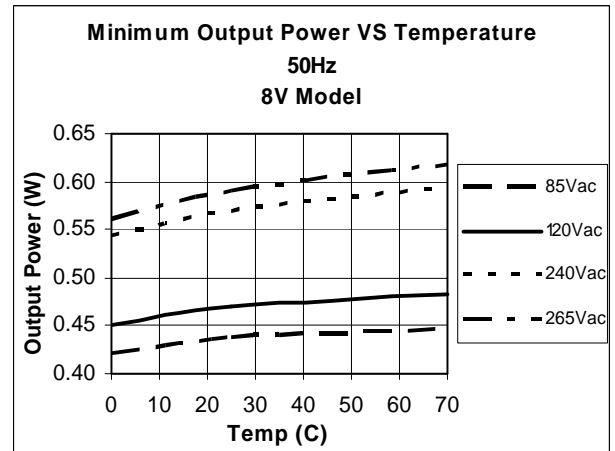
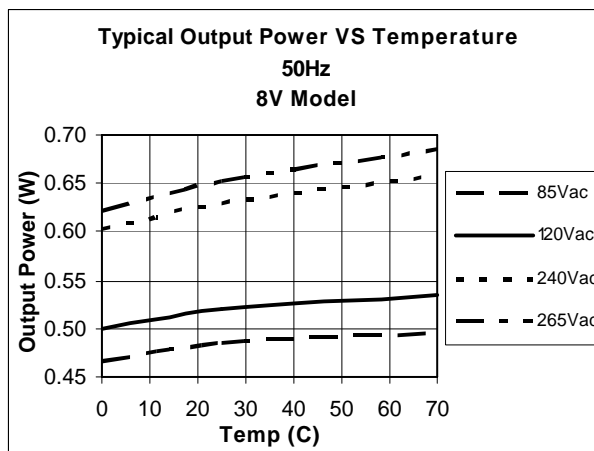
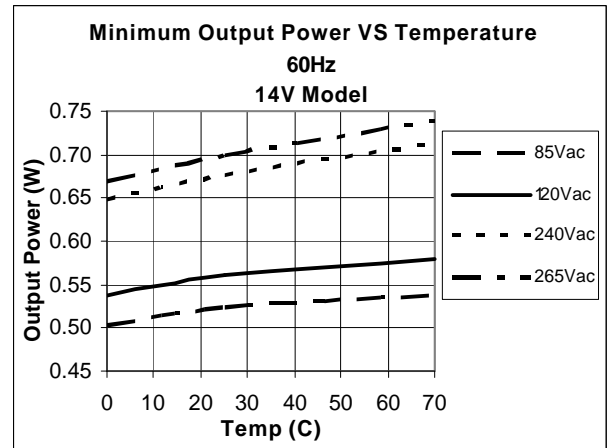
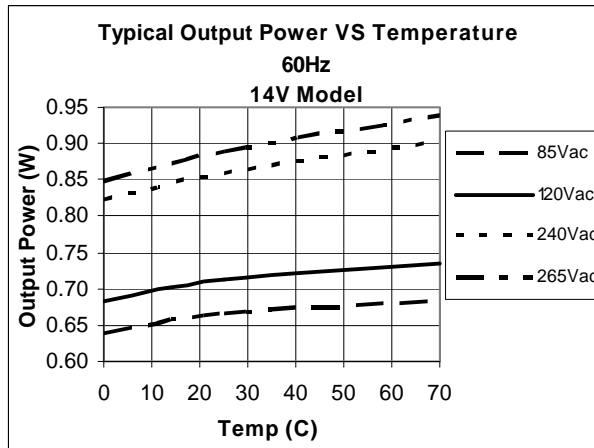
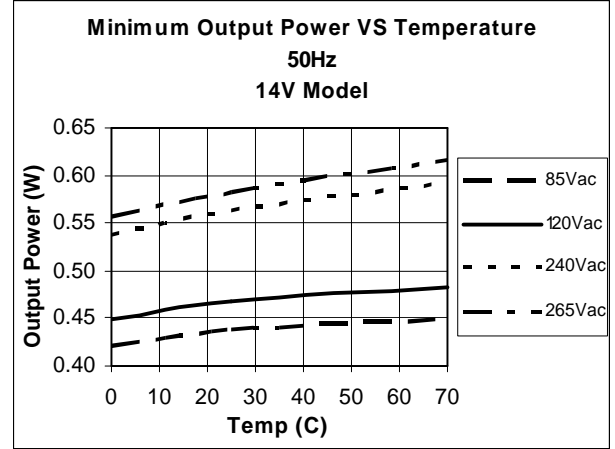
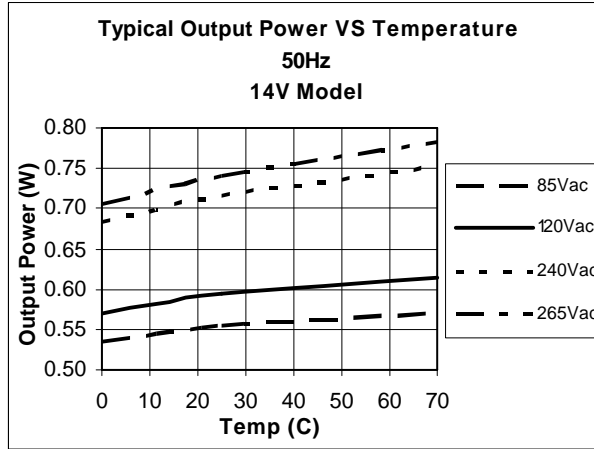



BIAS Power Supply Module BPS 0.5 Series Data Sheet

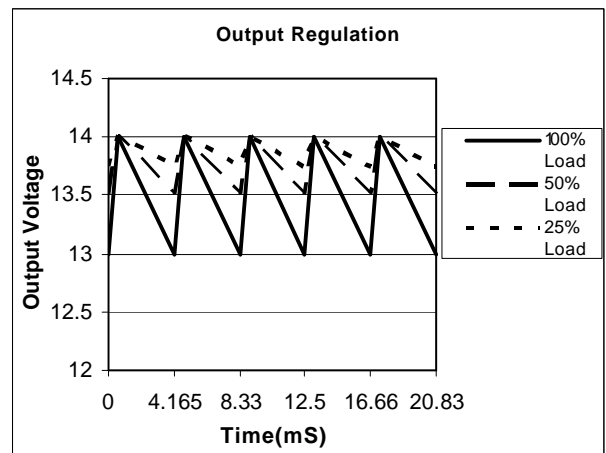
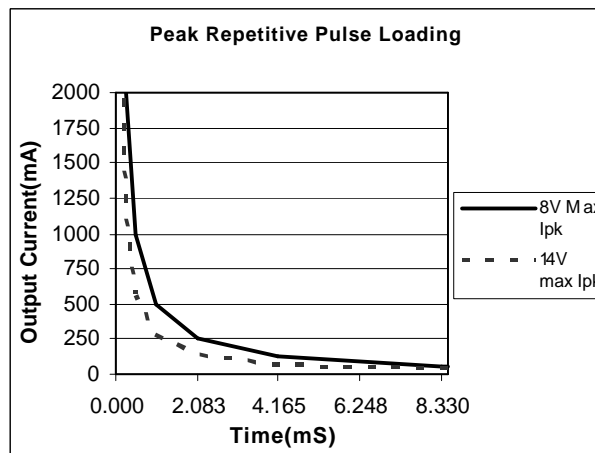
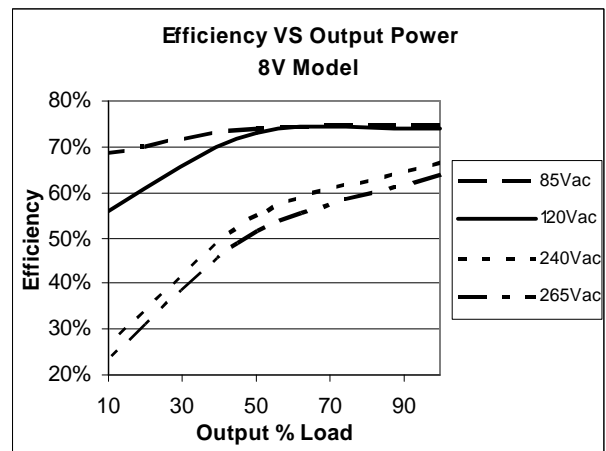
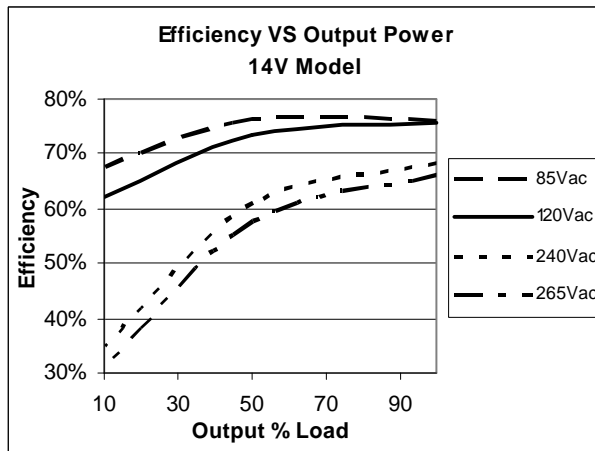
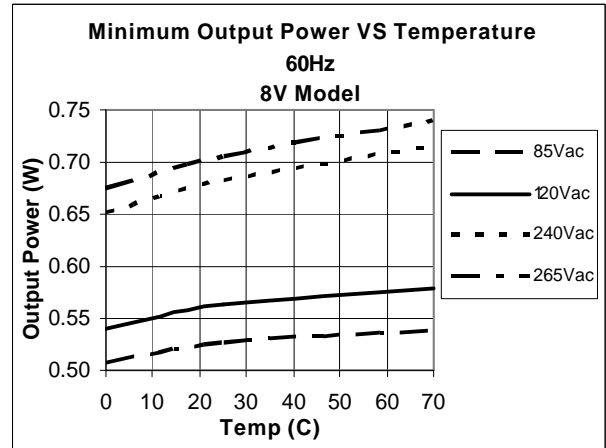
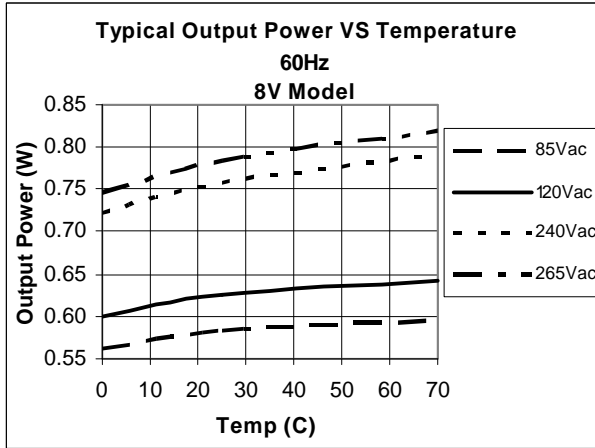



BIAS Power Supply Module BPS 0.5 Series Data Sheet

Part Number Designation

Part Number	Output Configuration	Vo	Vr
BPS 0.5-08-00	Single output	8 VDC	N/A
BPS 0.5-14-00	Single output	14 VDC	N/A
BPS 0.5-08-50	Dual Output	8 VDC	5 VDC

For custom configurations, contact BIAS Power.

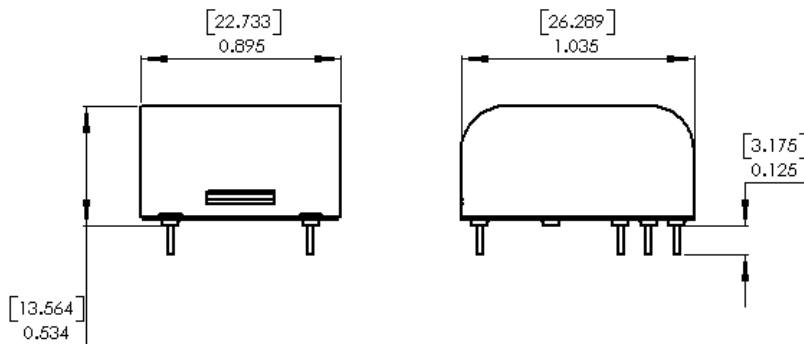

PIN DESIGNATOR	DESCRIPTION
L1	Input High
L2	Input Low
N/C	No Connection
Vo	Output
GND	Ground
Vr	Vr Output
N/C	No Connection

Recommended Land Pattern, top view

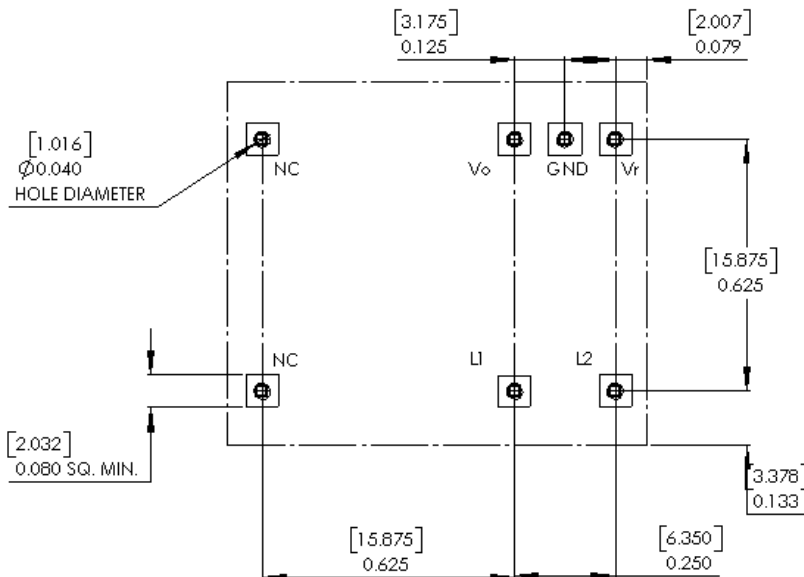

Isolation, Bottom View

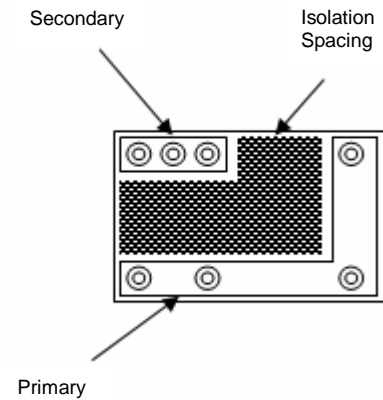

- NOTES**
1. Pins 0.025" [0.63 mm] square
 2. Pins extend 0.125" [3.17 mm] below stand-offs